

**MOTOR PERFORMANCE**

DISPLACEMENT	257 cc/Rev
THEORETICAL TORQUE	4,1 Nm/bar
CONT. PRESSURE	250 bar
HYDROSTATIC TEST PRESSURE	420 bar
MAX. SPEED	810 rpm
MAX. DRAIN PRESSURE	6 bar
MAX. POWER	50 kW
APPROXIMATED DRY WEIGHT	65 kg
TEMP. INTERVAL	-30 +70°C

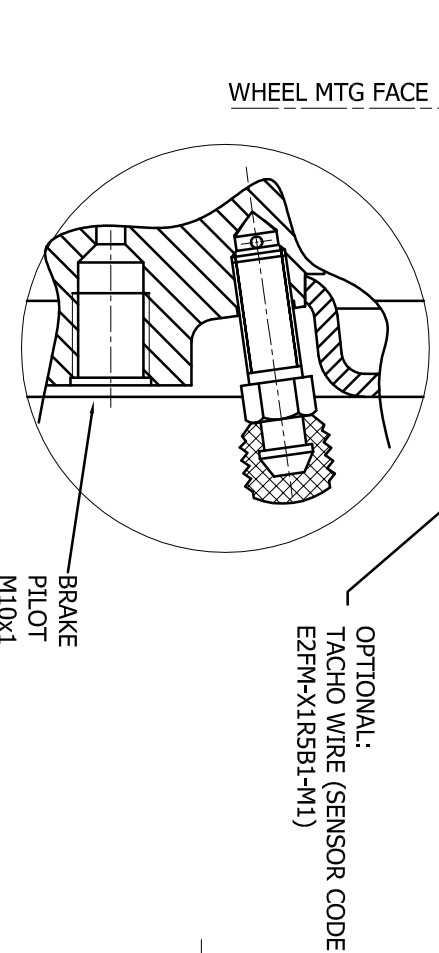

**POSITIVE BRAKE PERFORMANCE**

MAXIMUM BRAKING TORQUE	1600 Nm
MAXIMUM PILOT PRESSURE	100 bar
BRAKING TORQUE	16 Nm/bar

